

Data sheet

Preliminary Data Sheet

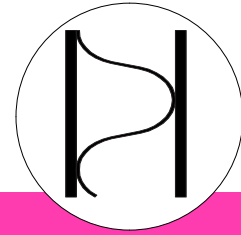

Panel type	Alu hl 10-03-10 hl / H15	
Top cover sheet		
Thickness of sheet	1.0 mm	(US: 0.039 in)
Surface	primered	
Alloy / Condition	EN AW-5754 H48	
Proof stress $R_{p0,2}$ [N/mm ²]	≥ 220	
Tensile stress R_m [N/mm ²]	≥ 280	
Back cover sheet		
Thickness of sheet	1.0 mm	(US: 0.039 in)
Surface	primered	
Alloy / Condition	EN AW-5754 H48	
Proof stress $R_{p0,2}$ [N/mm ²]	≥ 220	
Tensile stress R_m [N/mm ²]	≥ 280	
Dimensions		
Overall thickness [mm]*	15 ± 0.2	(US: 0.591 in ± 0.008 in)
Standard width [mm]*	1,500 -0/+6 ⁽⁴⁾	(US: 4.92 ft -0/+0.236 in) ⁽⁴⁾
Standard length [mm]*	3,000 -0/+6	(US: 9.84 ft -0/+0.236 in)
* other dimensions on request		
Mechanical and physical properties ⁽⁷⁾		
Weight [kg/m ²]	7.3	
Rigidity [Nmm ² /mm] ⁽²⁾ EI/b, longitudinal / transverse	9 E+6 / 3 E+6	
Bending moment [Nmm/mm] ⁽²⁾ Limit of elasticity M_{el} , longitudinal / transverse Max. bending moment M_{max} , longitudinal / transverse	≥ 3,200 / ≥ 1,000 ≥ 4,000 / ≥ 1,200	
Compressive strength [N/mm ²] punch-Ø 60.0 mm ⁽³⁾ punch-Ø 6.0 mm	≥ 2.2 ≥ 25	
Temperature stability ⁽⁶⁾	-40 to 100 °C (US: -40 to 212 °F)	
Approvals / Certificates	on request	

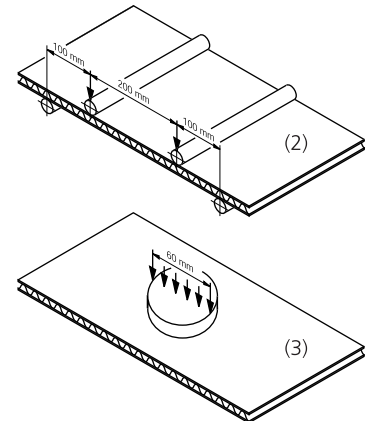

Alu hl 10-03-10 hl / H15

- (1) High Durable Polyester (HDP) coilcoated
Other colours and paint-systems on request
- (2) Bending test at room temperature
Depending on the direction of the corrugated core the bending tests are done:
longitudinal: bending axis perpendicular to the corrugation
4-point bending test following DIN 53293
transverse: bending axis parallel to the corrugation, 3-point bending test with
support distance L = 400mm, bending moment limited by shear failure
- (3) Pressure test at room temperature following DIN 53291
- (4) Border margin max. 5 mm (US: max. 0.197 in)
- (5) Cut by hammer shears
- (6) Others on request
- (7) Further characteristics can be supplied on demand