

Data sheet

One cover sheet
easy shaping

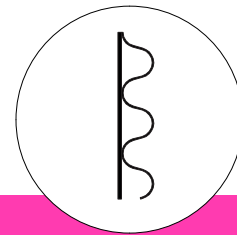

Panel type	Aluflex hl 05-02 hl / H4.7	
Top cover sheet		
Thickness of sheet	0.5 mm	(US: 0.020 in)
Surface	primered	
Alloy / Condition	EN AW-5182 H48	
Proof stress $R_{p0.2}$ [N/mm ²]	≥ 300	
Tensile stress R_m [N/mm ²]	≥ 330	
Corrugation		
Thickness of sheet	0.2 mm	(US: 0.007 in)
Surface	primered	
Dimensions		
Overall thickness [mm]*	4.7 ± 0.15	(US: 0.185 in ± 0.006 in)
Standard width [mm]*	1,500 -0/+6 ⁽⁴⁾	(US: 4.92 ft -0/+0.236 in) ⁽⁴⁾
Standard length [mm]*	Roll 25,000 ⁽⁵⁾	(US: 82.02 ft) -0/+2% ⁽⁵⁾
* other dimensions on request		
Mechanical and physical properties ⁽⁷⁾		
Weight [kg/m ²]	2.2	
Rigidity [Nmm ² /mm] ⁽²⁾ EI/b, longitudinal / transverse	110,000 / -	
Bending moment [Nmm/mm] ⁽²⁾ Limit of elasticity M_{el} , longitudinal / transverse Max. bending moment M_{max} , longitudinal / transverse	≥ 60 / - ≥ 110 / -	
10%-Compressive strength [N/mm ²] ⁽³⁾	≥ 1.4	
Temperature stability ⁽⁶⁾	-40 to 100 °C	
Approvals / Certificates	on request	

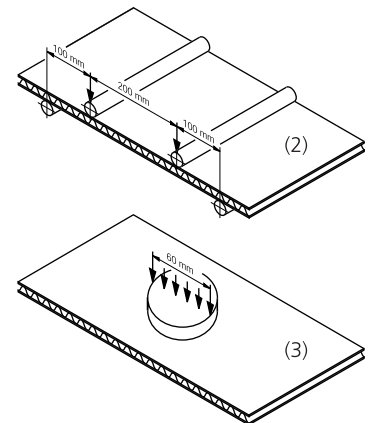

Aluflex hl 05-02 hl / H4.7

- (1) High Durable Polyester (HDP) coilcoated.
Other colours and paint-systems on request.
- (2) Bending test at room temperature following DIN 53293
Since the panel core is a corrugated sheet,
two different load cases have to be considered:
longitudinal: bending axis perpendicular to the corrugation
transverse: bending axis parallel to the corrugation
- (3) Pressure test at room temperature following DIN 53291
- (4) Border margin max. 5 mm (US: max. 0.197 in)
- (5) Cut by hammer shears
- (6) Others on request
- (7) Further characteristics can be supplied on demand