

# **Metawell**

*metal sandwich technology*

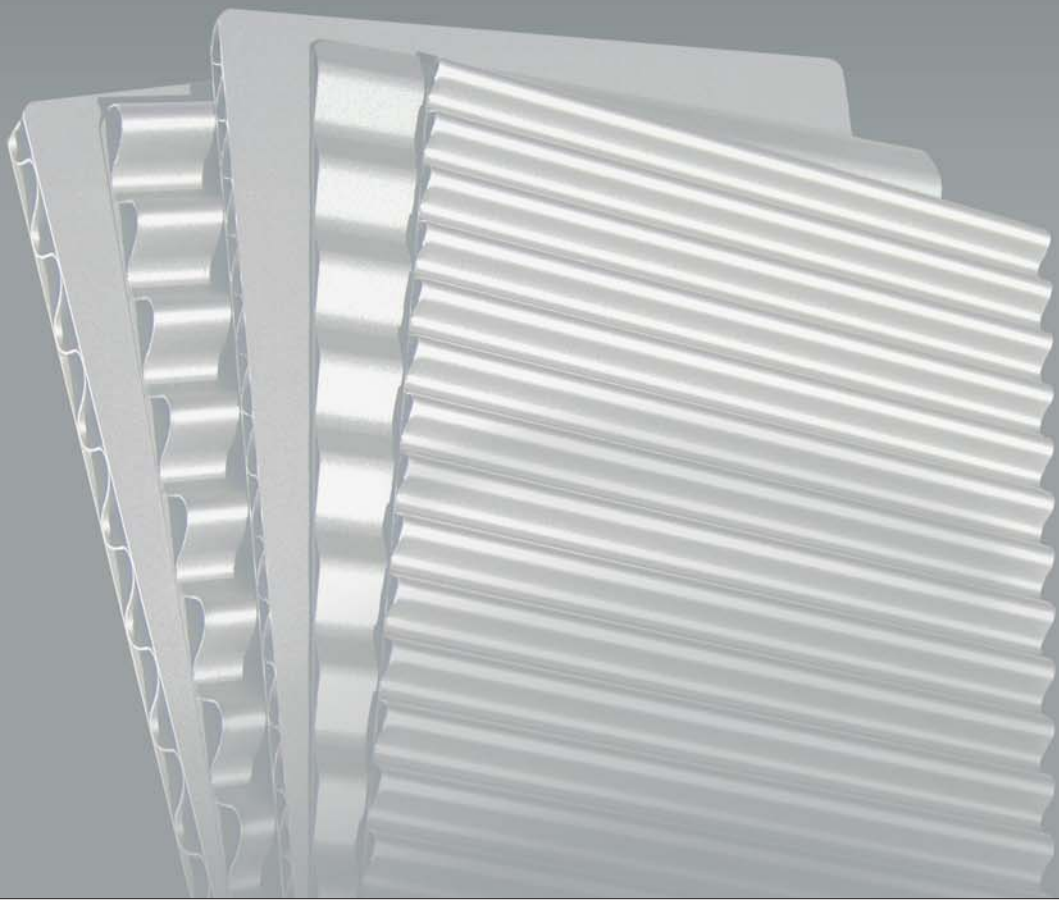
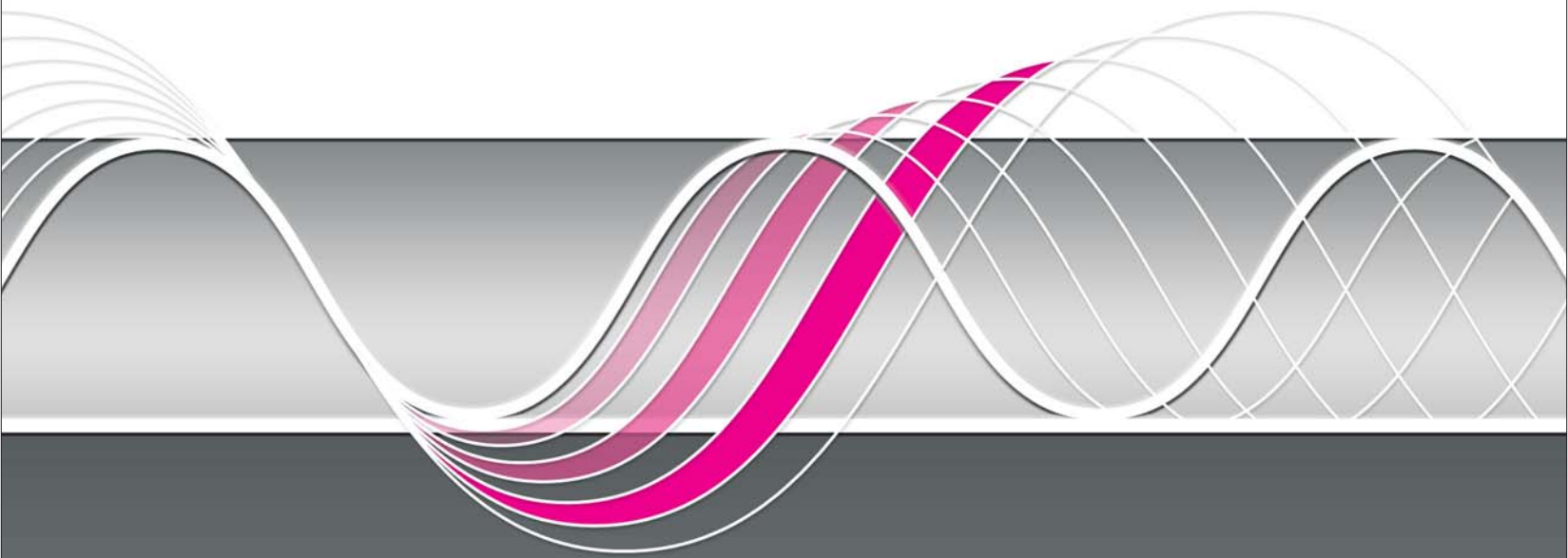

**ENGLISH**

# Metawell

## the lightweight panel

### • WHAT IS METAWELL?

Metawell is a patented aluminium panel of lightweight construction with a thin corrugation between two cover sheets.

### • ADVANTAGES

The ingeniously simple structure makes it a very light and extremely rigid sandwich panel with an even surface that provides significant savings in weight particularly when used in big formats. Since only little material is used simple processing with conventional tools is possible.

### • GLUING SYSTEM

The innovative Metawell hot-melt gluing system which is used to bond the corrugation to the cover sheets provides the benefits of conventional gluing systems. However, there is no creeping of the compound as is typical with viscoelastic hot-melt systems nor the classical danger of brittle failure which appears with brittle hard compounds. Moreover, the specific gluing system of Metawell warrants a high chemical, physical and thermal consistency.

### • STRENGTH AND STABILITY

The corrugated core itself possesses a high inherent stiffness. Thanks to its optimized geometry the corrugation and the cover sheet result in a harmonic compound. Therewith, Metawell reaches a particularly high static strength and an extremely good dynamic stability.

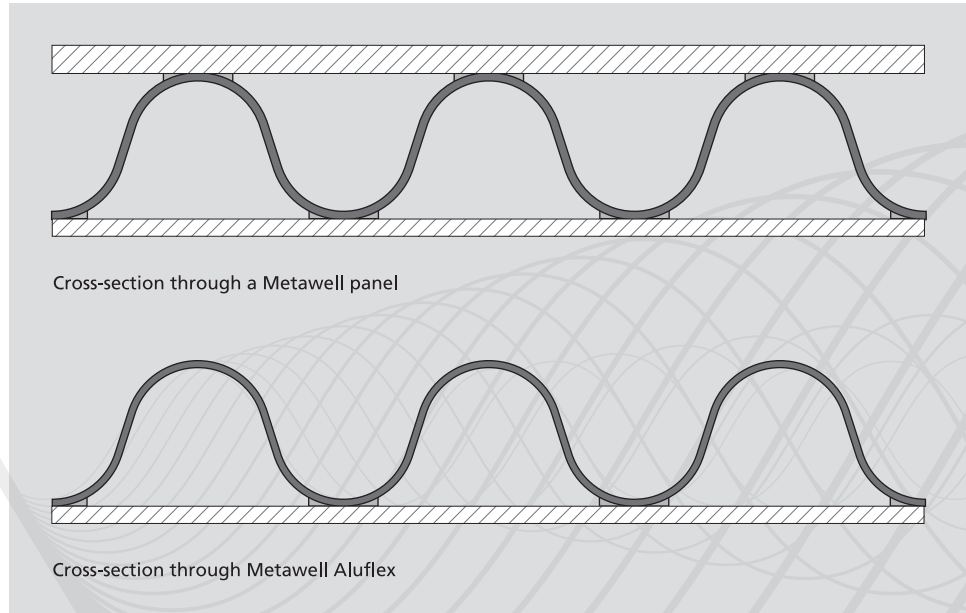

### • EXPERIENCE

For 25 years now Metawell has been used worldwide in the building sector (e.g. radiant cooling / heating ceilings, curtain-wall façades, interior construction), in transportation systems (railways, shipbuilding, automotive) and in machine-building.

### • DIVERSITY AND STANDARD PROGRAMM

Metawell is available with different cover sheets, surface coatings and corrugation heights, which can be chosen to match the later use. Thanks to the continuous production process almost any length can be supplied. For the short-time supply of small quantities, a standard program is available with panels of different characteristics.

For medium to big projects, we propose the production of special panels. In this case the particular parameters needed by the customer respectively the application will be considered when designing the panel.

### • ACCESSORIES

Information about accessories such as profiles or beadings can be obtained on request.

### • STORING AND HANDLING

Metawell panels should be stored horizontally in a dry and airy place. During handling and transport, care should be taken to ensure that the panel corners do not suffer damage. The wearing of safety gloves is recommended to avoid injuries.

### • RECYCLING

Metawell can be recycled without prior separation or sorting. Thus Metawell remains a precious material even after its service life.

Data sheet

Preliminary Data Sheet

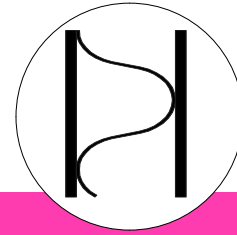

Panel type	Alu hl 10-03-10 hl / H15	
<b>Top cover sheet</b>		
<b>Thickness of sheet</b>	1.0 mm	(US: 0.039 in)
<b>Surface</b>	primered	
<b>Alloy / Condition</b>	EN AW-5754 H48	
<b>Proof stress</b> $R_{p0,2}$ [N/mm <sup>2</sup> ]	≥ 220	
<b>Tensile stress</b> $R_m$ [N/mm <sup>2</sup> ]	≥ 280	
<b>Back cover sheet</b>		
<b>Thickness of sheet</b>	1.0 mm	(US: 0.039 in)
<b>Surface</b>	primered	
<b>Alloy / Condition</b>	EN AW-5754 H48	
<b>Proof stress</b> $R_{p0,2}$ [N/mm <sup>2</sup> ]	≥ 220	
<b>Tensile stress</b> $R_m$ [N/mm <sup>2</sup> ]	≥ 280	
<b>Dimensions</b>		
<b>Overall thickness</b> [mm]*	15 ± 0.2	(US: 0.591 in ± 0.008 in)
<b>Standard width</b> [mm]*	1,500 -0/+6 <sup>(4)</sup>	(US: 4.92 ft -0/+0.236 in) <sup>(4)</sup>
<b>Standard length</b> [mm]*	3,000 -0/+6	(US: 9.84 ft -0/+0.236 in)
* other dimensions on request		
<b>Mechanical and physical properties</b> <sup>(7)</sup>		
<b>Weight</b> [kg/m <sup>2</sup> ]	7.3	
<b>Rigidity</b> [Nmm <sup>2</sup> /mm] <sup>(2)</sup> EI/b, longitudinal / transverse	9 E+6 / 3 E+6	
<b>Bending moment</b> [Nmm/mm] <sup>(2)</sup> Limit of elasticity $M_{el}$ , longitudinal / transverse Max. bending moment $M_{max}$ , longitudinal / transverse	≥ 3,200 / ≥ 1,000 ≥ 4,000 / ≥ 1,200	
<b>Compressive strength</b> [N/mm <sup>2</sup> ] punch-Ø 60.0 mm <sup>(3)</sup> punch-Ø 6.0 mm	≥ 2.2 ≥ 25	
<b>Temperature stability</b> <sup>(6)</sup>	-40 to 100 °C (US: -40 to 212 °F)	
<b>Approvals / Certificates</b>	on request	

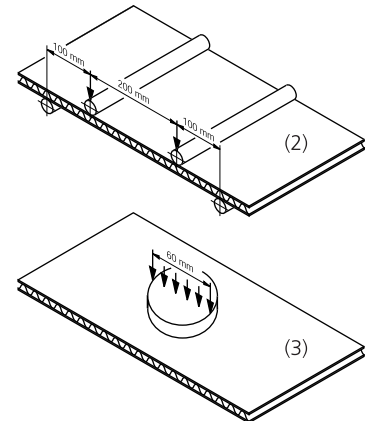

Alu hl 10-03-10 hl / H15

- (1) High Durable Polyester (HDP) coilcoated  
Other colours and paint-systems on request
- (2) Bending test at room temperature  
Depending on the direction of the corrugated core the bending tests are done:  
longitudinal: bending axis perpendicular to the corrugation  
4-point bending test following DIN 53293  
transverse: bending axis parallel to the corrugation, 3-point bending test with  
support distance L = 400mm, bending moment limited by shear failure
- (3) Pressure test at room temperature following DIN 53291
- (4) Border margin max. 5 mm (US: max. 0.197 in)
- (5) Cut by hammer shears
- (6) Others on request
- (7) Further characteristics can be supplied on demand

Data sheet

Very rigid panel  
with high load-bearing capacity

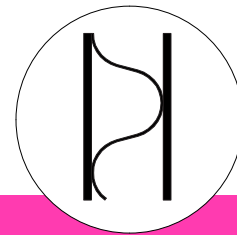

<b>Panel type</b>	<b>Alu hl 10-03-10 hl / H11.5</b>	
<b>Top cover sheet</b>		
<b>Thickness of sheet</b>	1.0 mm	(US: 0.039 in)
<b>Surface</b>	primered	
<b>Alloy / Condition</b>	EN AW-5754 H48	
<b>Proof stress</b> $R_{p0.2}$ [N/mm <sup>2</sup> ]	≥ 220	
<b>Tensile stress</b> $R_m$ [N/mm <sup>2</sup> ]	≥ 280	
<b>Back cover sheet</b>		
<b>Thickness of sheet</b>	1.0 mm	(US: 0.039 in)
<b>Surface</b>	primered	
<b>Alloy / Condition</b>	EN AW-5754 H48	
<b>Proof stress</b> $R_{p0.2}$ [N/mm <sup>2</sup> ]	≥ 220	
<b>Tensile stress</b> $R_m$ [N/mm <sup>2</sup> ]	≥ 280	
<b>Dimensions</b>		
<b>Overall thickness</b> [mm]*	11.5 ± 0.2	(US: 0.453 in ± 0.008 in)
<b>Standard width</b> [mm]*	1,500 -0/+6 <sup>(4)</sup>	(US: 4.92 ft -0/+0.236 in) <sup>(4)</sup>
<b>Standard length</b> [mm]*	3,000 -0/+6	(US: 9.84 ft -0/+0.236 in)
* other dimensions on request		
<b>Mechanical and physical properties</b> <sup>(7)</sup>		
<b>Weight</b> [kg/m <sup>2</sup> ]	7.2	
<b>Rigidity</b> [Nmm <sup>2</sup> /mm] <sup>(2)</sup> EI/b, longitudinal / transverse	5.1 E+6 / 3.5 E+6	
<b>Bending moment</b> [Nmm/mm] <sup>(2)</sup> Limit of elasticity $M_{el}$ , longitudinal / transverse Max. bending moment $M_{max}$ , longitudinal / transverse	≥ 2,200 / ≥ 900 ≥ 3,000 / ≥ 1,000	
<b>Compressive strength</b> [N/mm <sup>2</sup> ] <sup>(3)</sup>	≥ 3.75	
<b>Temperature stability</b> <sup>(6)</sup>	-40 to 100 °C (US: -40 to 212 °F)	
<b>Approvals / Certificates</b>	on request	

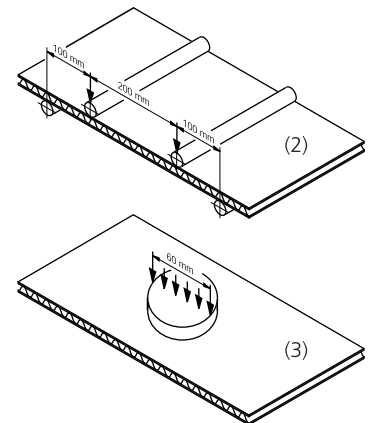

Alu hl 10-03-10 hl / H11.5

- (1) High Durable Polyester (HDP) coilcoated  
Other colours and paint-systems on request
- (2) Bending test at room temperature following DIN 53293  
Since the panel core is a corrugated sheet,  
two different load cases have to be considered:  
longitudinal: bending axis perpendicular to the corrugation  
transverse: bending axis parallel to the corrugation
- (3) Pressure test at room temperature following DIN 53291
- (4) Border margin max. 5 mm (US: max. 0.197 in)
- (5) Cut by hammer shears
- (6) Others on request
- (7) Further characteristics can be supplied on demand

Data sheet

Rigid panel  
primered

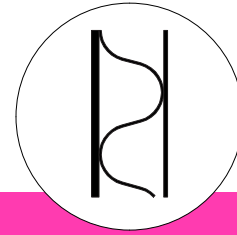

Panel type	Alu hl 10-03-05 hl / H10	
<b>Top cover sheet</b>		
<b>Thickness of sheet</b>	1.0 mm	(US: 0.039 in)
<b>Surface</b>	primered	
<b>Alloy / Condition</b>	EN AW-5754 H48	
<b>Proof stress</b> $R_{p0.2}$ [N/mm <sup>2</sup> ]	≥ 220	
<b>Tensile stress</b> $R_m$ [N/mm <sup>2</sup> ]	≥ 280	
<b>Back cover sheet</b>		
<b>Thickness of sheet</b>	0.5 mm	(US: 0.020 in)
<b>Surface</b>	primered	
<b>Alloy / Condition</b>	EN AW-5182 H48	
<b>Proof stress</b> $R_{p0.2}$ [N/mm <sup>2</sup> ]	≥ 300	
<b>Tensile stress</b> $R_m$ [N/mm <sup>2</sup> ]	≥ 330	
<b>Dimensions</b>		
<b>Overall thickness</b> [mm]*	10.0 ± 0.2	(US: 0.394 in ± 0.008 in)
<b>Standard width</b> [mm]*	1,500 -0/+6 <sup>(4)</sup>	(US: 4.92 ft -0/+0.236 in) <sup>(4)</sup>
<b>Standard length</b> [mm]*	3,000 -0/+6	(US: 9.84 ft -0/+0.236 in)
* other dimensions on request		
<b>Mechanical and physical properties <sup>(7)</sup></b>		
<b>Weight</b> [kg/m <sup>2</sup> ]	5.7	
<b>Rigidity</b> [Nmm <sup>2</sup> /mm] <sup>(2)</sup> EI/b, longitudinal / transverse	3.0 E+6 / 2.1 E+6	
<b>Bending moment</b> [Nmm/mm] <sup>(2)</sup> Limit of elasticity $M_{el}$ , längs / quer Max. bending moment $M_{max}$ , longitudinal / transverse	≥ 1,550 / ≥ 850 ≥ 2,000 / ≥ 1,000	
<b>Compressive strength</b> [N/mm <sup>2</sup> ] <sup>(3)</sup>	≥ 3.5	
<b>Temperature stability</b> <sup>(6)</sup>	-40 to 100 °C (US: -40 to 212 °F)	
<b>Approvals / Certificates</b>	on request	

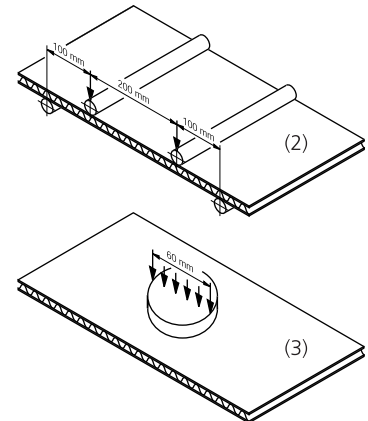

Alu hl 10-03-05 hl / H10

- (1) High Durable Polyester (HDP) coilcoated  
Other colours and paint-systems on request
- (2) Bending test at room temperature following DIN 53293  
Since the panel core is a corrugated sheet,  
two different load cases have to be considered:  
longitudinal: bending axis perpendicular to the corrugation  
transverse: bending axis parallel to the corrugation
- (3) Pressure test at room temperature following DIN 53291
- (4) Border margin max. 5 mm (US: max. 0.197 in)
- (5) Cut by hammer shears
- (6) Others on request
- (7) Further characteristics can be supplied on demand

Data sheet

White top sheet  
coilcoated

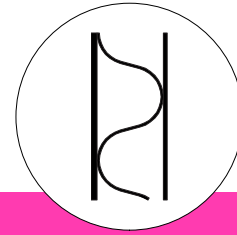

<b>Panel type</b>	<b>Alu cc 08-03-05 hl / H10</b>	
<b>Top cover sheet</b>		
<b>Thickness of sheet</b>	0.8 mm	(US: 0.032 in)
<b>Surface</b>	HDP RAL 9010 (white) <sup>(1)</sup>	
<b>Alloy / Condition</b>	EN AW-5754 H42	
<b>Proof stress</b> $R_{p0.2}$ [N/mm <sup>2</sup> ]	≥ 140	
<b>Tensile stress</b> $R_m$ [N/mm <sup>2</sup> ]	≥ 220	
<b>Back cover sheet</b>		
<b>Thickness of sheet</b>	0.5 mm	(US: 0.020 in)
<b>Surface</b>	primered	
<b>Alloy / Condition</b>	EN AW-5182 H48	
<b>Proof stress</b> $R_{p0.2}$ [N/mm <sup>2</sup> ]	≥ 300	
<b>Tensile stress</b> $R_m$ [N/mm <sup>2</sup> ]	≥ 330	
<b>Dimensions</b>		
<b>Overall thickness</b> [mm]*	10.0 ± 0.2	(US: 0.394 in ± 0.008 in)
<b>Standard width</b> [mm]*	1,500 -0/+6 <sup>(4)</sup>	(US: 4.92 ft -0/+0.236 in) <sup>(4)</sup>
<b>Standard length</b> [mm]*	3,000 -0/+6	(US: 9.84 ft -0/+0.236 in)
* other dimensions on request		
<b>Mechanical and physical properties</b> <sup>(7)</sup>		
<b>Weight</b> [kg/m <sup>2</sup> ]	5.2	
<b>Rigidity</b> [Nmm <sup>2</sup> /mm] <sup>(2)</sup> E I/b, longitudinal / transverse	2.2 E+6 / 1.6 E+6	
<b>Bending moment</b> [Nmm/mm] <sup>(2)</sup> Limit of elasticity $M_{el}$ , longitudinal / transverse Max. bending moment $M_{max}$ , longitudinal / transverse	≥ 1,250 / ≥ 750 ≥ 1,800 / ≥ 800	
<b>Compressive strength</b> [N/mm <sup>2</sup> ] <sup>(3)</sup>	≥ 3.2	
<b>Temperature stability</b> <sup>(6)</sup>	-40 to 100 °C (US: -40 to 212 °F)	
<b>Approvals / Certificates</b>	on request	

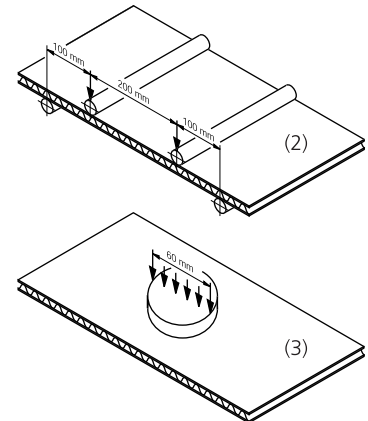

Alu cc 08-03-05 hl / H10

- (1) High Durable Polyester (HDP) coilcoated.  
Other colours and paint-systems on request.
- (2) Bending test at room temperature following DIN 53293  
Since the panel core is a corrugated sheet,  
two different load cases have to be considered:  
longitudinal: bending axis perpendicular to the corrugation  
transverse: bending axis parallel to the corrugation
- (3) Pressure test at room temperature following DIN 53291
- (4) Border margin max. 5 mm (US: max. 0.197 in)
- (5) Cut by hammer shears
- (6) Others on request
- (7) Further characteristics can be supplied on demand

**Protective film**

If panels are supplied with a protective film, it must be taken off not later than 6 months after delivery. Bigger temperature changes and exposure to direct sunlight should be avoided since this may reduce the duration. Partial removal of the film, e.g. during processing, may lead to dirt marks along the borders.

Data sheet

High compressive strength  
ideal for floors

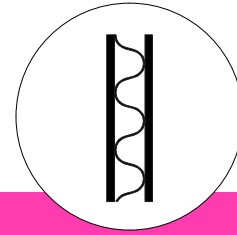

Panel type	Alu hl 10-03-10 hl / H6	
<b>Top cover sheet</b>		
Thickness of sheet	1.0 mm	(US: 0.039 in)
Surface	primered	
Alloy / Condition	EN AW-5754 H48	
Proof stress $R_{p0,2}$ [N/mm <sup>2</sup> ]	≥ 220	
Tensile stress $R_m$ [N/mm <sup>2</sup> ]	≥ 280	
<b>Back cover sheet</b>		
Thickness of sheet	1.0 mm	(US: 0.039 in)
Surface	primered	
Alloy / Condition	EN AW-5754 H48	
Proof stress $R_{p0,2}$ [N/mm <sup>2</sup> ]	≥ 220	
Tensile stress $R_m$ [N/mm <sup>2</sup> ]	≥ 280	
<b>Dimensions</b>		
Overall thickness [mm]*	6 ± 0.2	(US: 0.236 in ± 0.008 in)
Standard width [mm]*	1,500 -0/+6 <sup>(4)</sup>	(US: 4.92 ft -0/+0.236 in) <sup>(4)</sup>
Standard length [mm]*	3,000 -0/+6	(US: 9.84 ft -0/+0.236 in)
* other dimensions on request		
<b>Mechanical and physical properties<sup>(7)</sup></b>		
Weight [kg/m <sup>2</sup> ]	6.9	
Rigidity [Nmm <sup>2</sup> /mm] <sup>(2)</sup> EI/b, longitudinal / transverse	1.1 E+6 / 1.0 E+6	
Bending moment [Nmm/mm] <sup>(2)</sup> Limit of elasticity $M_{el}$ , longitudinal / transverse Max. bending moment $M_{max}$ , longitudinal / transverse	≥ 1,000 / ≥ 900 ≥ 1,250 / ≥ 1,000	
Compressive strength [N/mm <sup>2</sup> ] <sup>(3)</sup>	≥ 12	
Temperature stability <sup>(6)</sup>	-40 to 100 °C (US: -40 to 212 °F)	
Approvals / Certificates	on request	

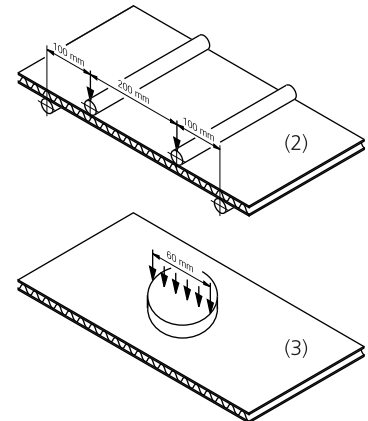

Alu hl 10-03-10 hl / H6

- (1) High Durable Polyester (HDP) coilcoated  
Other colours and paint-systems on request
- (2) Bending test at room temperature following DIN 53293  
Since the panel core is a corrugated sheet,  
two different load cases have to be considered:  
longitudinal: bending axis perpendicular to the corrugation  
transverse: bending axis parallel to the corrugation
- (3) Pressure test at room temperature following DIN 53291
- (4) Border margin max. 5 mm (US: max. 0.197 in)
- (5) Cut by hammer shears
- (6) Others on request
- (7) Further characteristics can be supplied on demand

Data sheet

White top sheet  
coilcoated

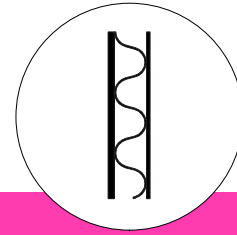

<b>Panel type</b>	<b>Alu cc 08-02-05 hl / H5.5</b>	
<b>Top cover sheet</b>		
<b>Thickness of sheet</b>	0.8 mm	(US: 0.032 in)
<b>Surface</b>	HDP RAL 9010 (white) <sup>(1)</sup>	
<b>Alloy / Condition</b>	EN AW-5754 H42	
<b>Proof stress</b> $R_{p0.2}$ [N/mm <sup>2</sup> ]	≥ 140	
<b>Tensile stress</b> $R_m$ [N/mm <sup>2</sup> ]	≥ 220	
<b>Back cover sheet</b>		
<b>Thickness of sheet</b>	0.5 mm	(US: 0.020 in)
<b>Surface</b>	primered	
<b>Alloy / Condition</b>	EN AW-5182 H48	
<b>Proof stress</b> $R_{p0.2}$ [N/mm <sup>2</sup> ]	≥ 300	
<b>Tensile stress</b> $R_m$ [N/mm <sup>2</sup> ]	≥ 330	
<b>Dimensions</b>		
<b>Overall thickness</b> [mm]*	5.5 ± 0.15	(US: 0.217 in ± 0.006 in)
<b>Standard width</b> [mm]*	1,500 -0/+6 <sup>(4)</sup>	(US: 4.92 ft -0/+0.236 in) <sup>(4)</sup>
<b>Standard length</b> [mm]*	3,000 -0/+6	(US: 9.84 ft -0/+0.236 in)
* other dimensions on request		
<b>Mechanical and physical properties</b> <sup>(7)</sup>		
<b>Weight</b> [kg/m <sup>2</sup> ]	4.55	
<b>Rigidity</b> [Nmm <sup>2</sup> /mm] <sup>(2)</sup> EI/b, longitudinal / transverse	660,000 / 600,000	
<b>Bending moment</b> [Nmm/mm] <sup>(2)</sup> Limit of elasticity $M_{el}$ , longitudinal / transverse Max. bending moment $M_{max}$ , longitudinal / transverse	≥ 490 / ≥ 460 ≥ 830 / ≥ 580	
<b>Compressive strength</b> [N/mm <sup>2</sup> ] <sup>(3)</sup>	≥ 3.2	
<b>Temperature stability</b> <sup>(6)</sup>	-40 to 100 °C (US: -40 to 212 °F)	
<b>Approvals / Certificates</b>	on request	

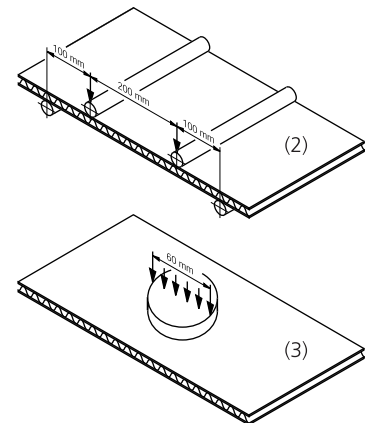

- (1) High Durable Polyester (HDP) coilcoated.  
Other colours and paint-systems on request.
- (2) Bending test at room temperature following DIN 53293  
Since the panel core is a corrugated sheet,  
two different load cases have to be considered:  
longitudinal: bending axis perpendicular to the corrugation  
transverse: bending axis parallel to the corrugation
- (3) Pressure test at room temperature following DIN 53291
- (4) Border margin max. 5 mm (US: max. 0.197 in)
- (5) Cut by hammer shears
- (6) Others on request
- (7) Further characteristics can be supplied on demand

**Protective film**

If panels are supplied with a protective film, it must be taken off not later than 6 months after delivery. Bigger temperature changes and exposure to direct sunlight should be avoided since this may reduce the duration. Partial removal of the film, e.g. during processing, may lead to dirt marks along the borders.

Alu cc 08-02-05 hl / H5.5

Data sheet

All-round-panel  
primered

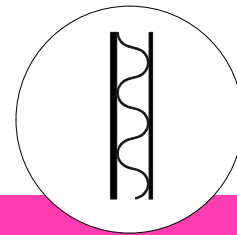

<b>Panel type</b>	<b>Alu hl 08-02-05 hl / H5.5</b>	
<b>Top cover sheet</b>		
<b>Thickness of sheet</b>	0.8 mm	(US: 0.032 in)
<b>Surface</b>	primered	
<b>Alloy / Condition</b>	EN AW-5754 H42	
<b>Proof stress</b> $R_{p0.2}$ [N/mm <sup>2</sup> ]	≥ 140	
<b>Tensile stress</b> $R_m$ [N/mm <sup>2</sup> ]	≥ 220	
<b>Back cover sheet</b>		
<b>Thickness of sheet</b>	0.5 mm	(US: 0.020 in)
<b>Surface</b>	primered	
<b>Alloy / Condition</b>	EN AW-5182 H48	
<b>Proof stress</b> $R_{p0.2}$ [N/mm <sup>2</sup> ]	≥ 300	
<b>Tensile stress</b> $R_m$ [N/mm <sup>2</sup> ]	≥ 330	
<b>Dimensions</b>		
<b>Overall thickness</b> [mm]*	5.5 ± 0.15	(US: 0.217 in ± 0.006 in)
<b>Standard width</b> [mm]*	1,500 -0/+6 <sup>(4)</sup>	(US: 4.92 ft -0/+0.236 in) <sup>(4)</sup>
<b>Standard length</b> [mm]*	3,000 -0/+6	(US: 9.84 ft -0/+0.236 in)
* other dimensions on request		
<b>Mechanical and physical properties <sup>(7)</sup></b>		
<b>Weight</b> [kg/m <sup>2</sup> ]	4.5	
<b>Rigidity</b> [Nmm <sup>2</sup> /mm] <sup>(2)</sup> EI/b, longitudinal / transverse	660,000 / 600,000	
<b>Bending moment</b> [Nmm/mm] <sup>(2)</sup> Limit of elasticity $M_{el}$ , longitudinal / transverse Max. bending moment $M_{max}$ , longitudinal / transverse	≥ 490 / ≥ 460 ≥ 830 / ≥ 580	
<b>Compressive strength</b> [N/mm <sup>2</sup> ] <sup>(3)</sup>	≥ 3.2	
<b>Temperature stability</b> <sup>(6)</sup>	-40 to 100 °C (US: -40 to 212 °F)	
<b>Approvals / Certificates</b>	on request	

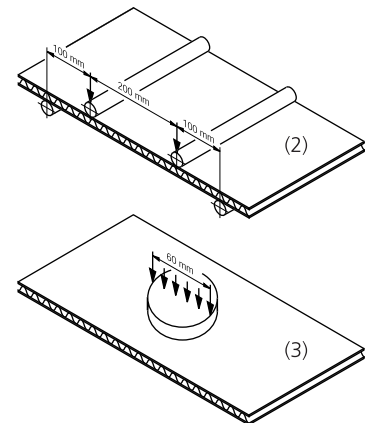

Alu hl 08-02-05 hl / H5.5

- (1) High Durable Polyester (HDP) coilcoated  
Other colours and paint-systems on request
- (2) Bending test at room temperature following DIN 53293  
Since the panel core is a corrugated sheet,  
two different load cases have to be considered:  
longitudinal: bending axis perpendicular to the corrugation  
transverse: bending axis parallel to the corrugation
- (3) Pressure test at room temperature following DIN 53291
- (4) Border margin max. 5 mm (US: max. 0.197 in)
- (5) Cut by hammer shears
- (6) Others on request
- (7) Further characteristics can be supplied on demand

Data sheet

Light panel  
primered

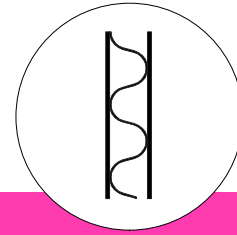

<b>Panel type</b>	<b>Alu hl 05-02-05 hl / H6</b>	
<b>Top cover sheet</b>		
<b>Thickness of sheet</b>	0.5 mm	(US: 0.020 in)
<b>Surface</b>	primered	
<b>Alloy / Condition</b>	EN AW-5182 H48	
<b>Proof stress</b> $R_{p0,2}$ [N/mm <sup>2</sup> ]	≥ 300	
<b>Tensile stress</b> $R_m$ [N/mm <sup>2</sup> ]	≥ 330	
<b>Back cover sheet</b>		
<b>Thickness of sheet</b>	0.5 mm	(US: 0.020 in)
<b>Surface</b>	primered	
<b>Alloy / Condition</b>	EN AW-5182 H48	
<b>Proof stress</b> $R_{p0,2}$ [N/mm <sup>2</sup> ]	≥ 300	
<b>Tensile stress</b> $R_m$ [N/mm <sup>2</sup> ]	≥ 330	
<b>Dimensions</b>		
<b>Overall thickness</b> [mm]*	6 ± 0.15	(US: 0.236 in ± 0.006 in)
<b>Standard width</b> [mm]*	1,500 -0/+6 <sup>(4)</sup>	(US: 4.92 ft -0/+0.236 in) <sup>(4)</sup>
<b>Standard length</b> [mm]*	3,000 -0/+6	(US: 9.84 ft -0/+0.236 in)
* other dimensions on request		
<b>Mechanical and physical properties <sup>(7)</sup></b>		
<b>Weight</b> [kg/m <sup>2</sup> ]	3.8	
<b>Rigidity</b> [Nmm <sup>2</sup> /mm] <sup>(2)</sup> EI/b, longitudinal / transverse	740,000 / 600,000	
<b>Bending moment</b> [Nmm/mm] <sup>(2)</sup> Limit of elasticity $M_{el}$ , longitudinal / transverse Max. bending moment $M_{max}$ , longitudinal / transverse	≥ 700 / ≥ 480 ≥ 950 / ≥ 500	
<b>Compressive strength</b> [N/mm <sup>2</sup> ] <sup>(3)</sup>	≥ 2.4	
<b>Temperature stability</b> <sup>(6)</sup>	-40 to 100 °C (US: -40 to 212 °F)	
<b>Approvals / Certificates</b>	on request	

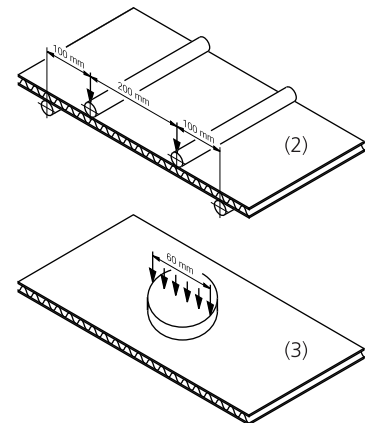

Alu hl 05-02-05 hl / H6

- (1) High Durable Polyester (HDP) coilcoated  
Other colours and paint-systems on request
- (2) Bending test at room temperature following DIN 53293  
Since the panel core is a corrugated sheet,  
two different load cases have to be considered:  
longitudinal: bending axis perpendicular to the corrugation  
transverse: bending axis parallel to the corrugation
- (3) Pressure test at room temperature following DIN 53291
- (4) Border margin max. 5 mm (US: max. 0.197 in)
- (5) Cut by hammer shears
- (6) Others on request
- (7) Further characteristics can be supplied on demand

## Data sheet

One cover sheet  
easy shaping

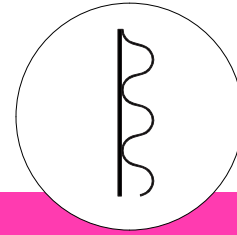

<b>Panel type</b>	<b>Aluflex hl 05-02 hl / H4.7</b>	
<b>Top cover sheet</b>		
<b>Thickness of sheet</b>	0.5 mm	(US: 0.020 in)
<b>Surface</b>	primered	
<b>Alloy / Condition</b>	EN AW-5182 H48	
<b>Proof stress</b> $R_{p0.2}$ [N/mm <sup>2</sup> ]	≥ 300	
<b>Tensile stress</b> $R_m$ [N/mm <sup>2</sup> ]	≥ 330	
<b>Corrugation</b>		
<b>Thickness of sheet</b>	0.2 mm	(US: 0.007 in)
<b>Surface</b>	primered	
<b>Dimensions</b>		
<b>Overall thickness</b> [mm]*	4.7 ± 0.15	(US: 0.185 in ± 0.006 in)
<b>Standard width</b> [mm]*	1,500 -0/+6 <sup>(4)</sup>	(US: 4.92 ft -0/+0.236 in) <sup>(4)</sup>
<b>Standard length</b> [mm]*	Roll 25,000 <sup>(5)</sup>	(US: 82.02 ft) -0/+2% <sup>(5)</sup>
* other dimensions on request		
<b>Mechanical and physical properties</b> <sup>(7)</sup>		
<b>Weight</b> [kg/m <sup>2</sup> ]	2.2	
<b>Rigidity</b> [Nmm <sup>2</sup> /mm] <sup>(2)</sup> EI/b, longitudinal / transverse	110,000 / -	
<b>Bending moment</b> [Nmm/mm] <sup>(2)</sup> Limit of elasticity $M_{el}$ , longitudinal / transverse Max. bending moment $M_{max}$ , longitudinal / transverse	≥ 60 / - ≥ 110 / -	
<b>10%-Compressive strength</b> [N/mm <sup>2</sup> ] <sup>(3)</sup>	≥ 1.4	
<b>Temperature stability</b> <sup>(6)</sup>	-40 to 100 °C	
<b>Approvals / Certificates</b>	on request	

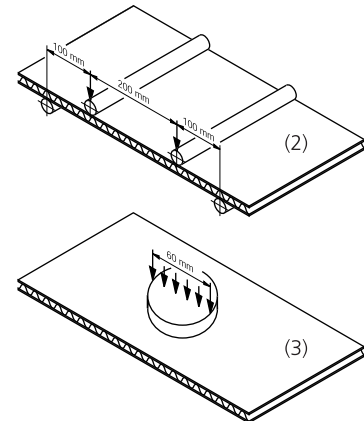

Aluflex hl 05-02 hl / H4.7

- (1) High Durable Polyester (HDP) coilcoated.  
Other colours and paint-systems on request.
- (2) Bending test at room temperature following DIN 53293  
Since the panel core is a corrugated sheet,  
two different load cases have to be considered:  
longitudinal: bending axis perpendicular to the corrugation  
transverse: bending axis parallel to the corrugation
- (3) Pressure test at room temperature following DIN 53291
- (4) Border margin max. 5 mm (US: max. 0.197 in)
- (5) Cut by hammer shears
- (6) Others on request
- (7) Further characteristics can be supplied on demand

## Data sheet

Decorative wavy look

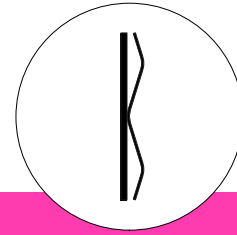

Panel type	Aluflex hl 08-03 hl / H3-M	
<b>Cover sheet</b>		
<b>Thickness of sheet</b>	0.8 mm	(US: 0.032 in)
<b>Surface</b>	primered	
<b>Alloy / Condition</b>	EN AW-5754 H42	
<b>Proof stress</b> $R_{p0.2}$ [N/mm <sup>2</sup> ]	≥ 140	
<b>Tensile stress</b> $R_m$ [N/mm <sup>2</sup> ]	≥ 220	
<b>Corrugation</b>		
<b>Thickness of sheet</b>	0.3 mm	(US: 0.012 in)
<b>Surface</b>	primered	
<b>Dimensions</b>		
<b>Overall thickness</b> [mm]*	3.0 ± 0.2	(US: 0.118 in ± 0.008 in)
<b>Standard width</b> [mm]*	1,500 -0/+6 <sup>(4)</sup>	(US: 4.92 ft -0/+0.236 in) <sup>(4)</sup>
<b>Standard length</b> [mm]*	3,000 -0/+10 <sup>(5)</sup>	(US: 9.84 ft -0/+0.394 in)
* other dimensions on request		
<b>Mechanical and physical properties</b> <sup>(7)</sup>		
<b>Weight</b> [kg/m <sup>2</sup> ]	3.3	
<b>Rigidity</b> [Nmm <sup>2</sup> /mm] <sup>(2)</sup> EI/b, longitudinal / transverse	- / -	
<b>Bending moment</b> [Nmm/mm] <sup>(2)</sup> Limit of elasticity $M_{el}$ , longitudinal / transverse Max. bending moment $M_{max}$ , longitudinal / transverse	- / - - / -	
<b>10%- Compressive strength</b> [N/mm <sup>2</sup> ] <sup>(3)</sup>	-	
<b>Temperature stability</b> <sup>(6)</sup>	-40 to 100 °C (US: -40 to 212 °F)	
<b>Approvals / Certificates</b>	on request	

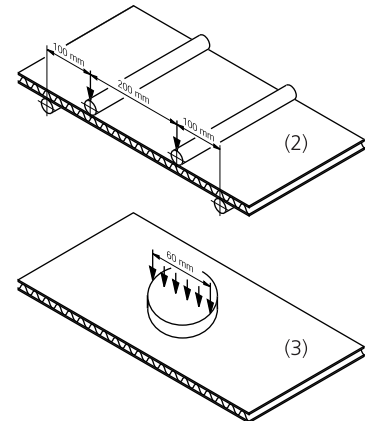

Aluflex hl 08-03 hl / H3-M

- (1) High Durable Polyester (HDP) coilcoated  
Other colours and paint-systems on request.
- (2) Bending test at room temperature following DIN 53293  
Since the panel core is a corrugated sheet,  
two different load cases have to be considered:  
longitudinal: bending axis perpendicular to the corrugation  
transverse: bending axis parallel to the corrugation
- (3) Pressure test at room temperature following DIN 53291
- (4) Border margin max. 5 mm (US: max. 0.197 in)
- (5) Cut by hammer shears
- (6) Others on request
- (7) Further characteristics can be supplied on demand